

Isokern Magnum 42" Fireplace

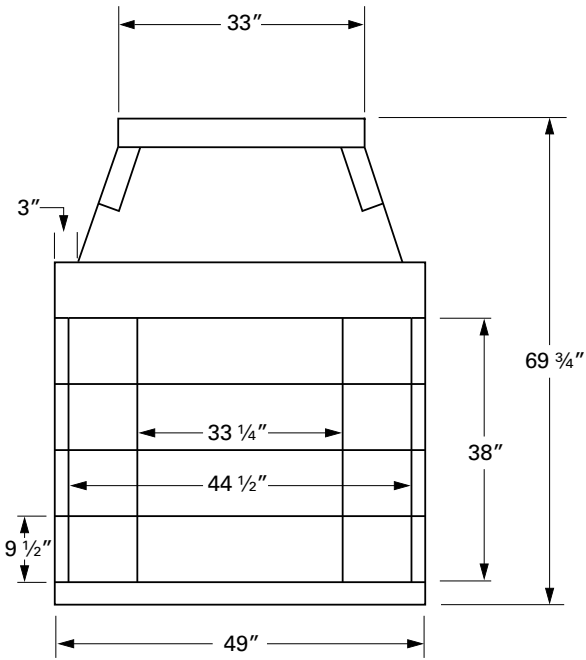

6899 Phillips Industrial Blvd. • Jacksonville, FL 32256

Project Name: _____ Location: _____



Front View

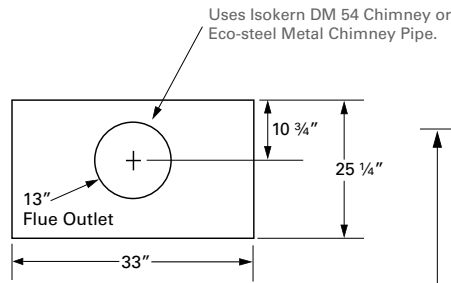

Top View

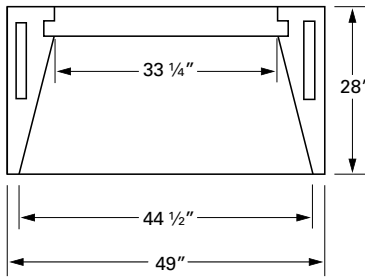

Plan View

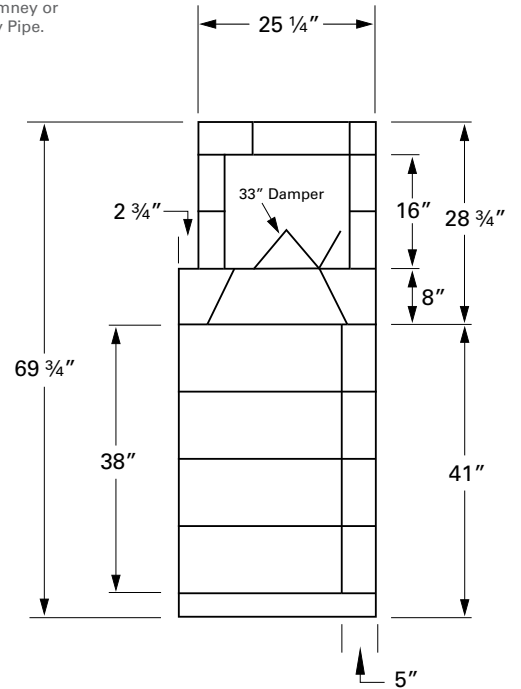

Side View

FIREPLACE OPTIONS

- Hearth Height: _____
- Brick Type: _____
- Brick Color: _____
- Brick Pattern: _____
- Damper: _____
- Chimney Type: _____
- Offset: _____
- Other Options: _____
- Spark Arrestor/Termination: _____
- Energex RSHT Chimney Fan: _____
- Decorative Termination: _____
- Gas Log Set: _____
- Wood Grate: _____

Notes: _____

MINIMUM FRAMING DIMENSIONS

Framing dimensions maintain 1 1/2" clearance to combustibles. Refer to product manual for further installation instructions.

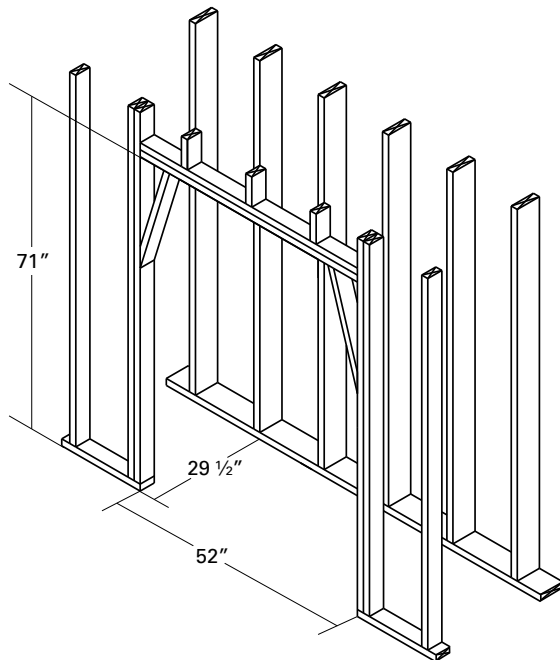

The total weight for the Magnum 42" fireplace is approximately 1420 lbs. This dry weight includes fireplace pumice components only, additional weight from mortar, damper, firebrick and chimney not included.